

# Advanced TCA®

## SB ATCA1000 KEY FEATURES

- Flexible storage-centric ATCA blade offers both PCI-E (AdvancedMC.1) and Storage (AdvancedMC.3) interconnect
- Supports four mid height AMC modules
- Supports both 1 and 10 G Ethernet ATCA Fabric connections as well as 1G Ethernet base connectivity
- Supports SAS, SATA or Solid State storage AMCs
- Supports PCI-E based AMCs, including storage controllers for connectivity to external disk arrays
- Rear transition module support
- On-board SAS/SATA controller with integrated RAID capability
- Powerful Freescale MPC8548 processor for storage serving applications

## SANBlaze ATCA1000 Storage Blade

The SANBlaze ATCA1000 storage blade is a single slot, ATCA module that can support up to 4 AdvancedMC (AMC) modules. The architecture of this module is optimized to provide a flexible and robust in-chassis ATCA storage platform to build high performance, highly reliable and redundant storage configurations.

The ATCA1000 has an on-board intelligent SAS/SATA controller, providing RAID functionality without the need for host CPU cycles or an external controller. The controller supports Raid 0, 1 and 10E. The controller drives SAS/SATA signals to each of the AMC sites, as well as to a Rear Transition Module (RTM), if required.

An onboard PCI-E switch provides additional AMC expansion options, allowing PCI-E based AMC cards to be integrated onto the board in addition to storage AMCs. PCI-E signaling routed from an RTM positions the ATCA1000 as a high performance, cost effective, in-chassis ATCA PCI-E expansion option.

1G Ethernet connectivity to the base and 10G Ethernet connectivity to the backplane fabric allow for high performance, in-chassis storage systems to be architected based on application. A powerful Freescale Power QUICC III MPC8548 running at up to 1.2 GHz provides the horsepower to serve storage over the backplane utilizing either optional NAS or iSCSI stacks.

Four storage AMCs can be used in the system to provide up to 1 TB of in-chassis storage. SAS, SATA or Solid State AMC hard drive modules are available to meet a range of capacity, performance and environmental requirements. Additionally, PCI-E based storage adapters can be integrated providing connectivity options to external arrays if required.

# SB ATCA1000 Storage Blade

## ATCA1000 Summary Block Diagram

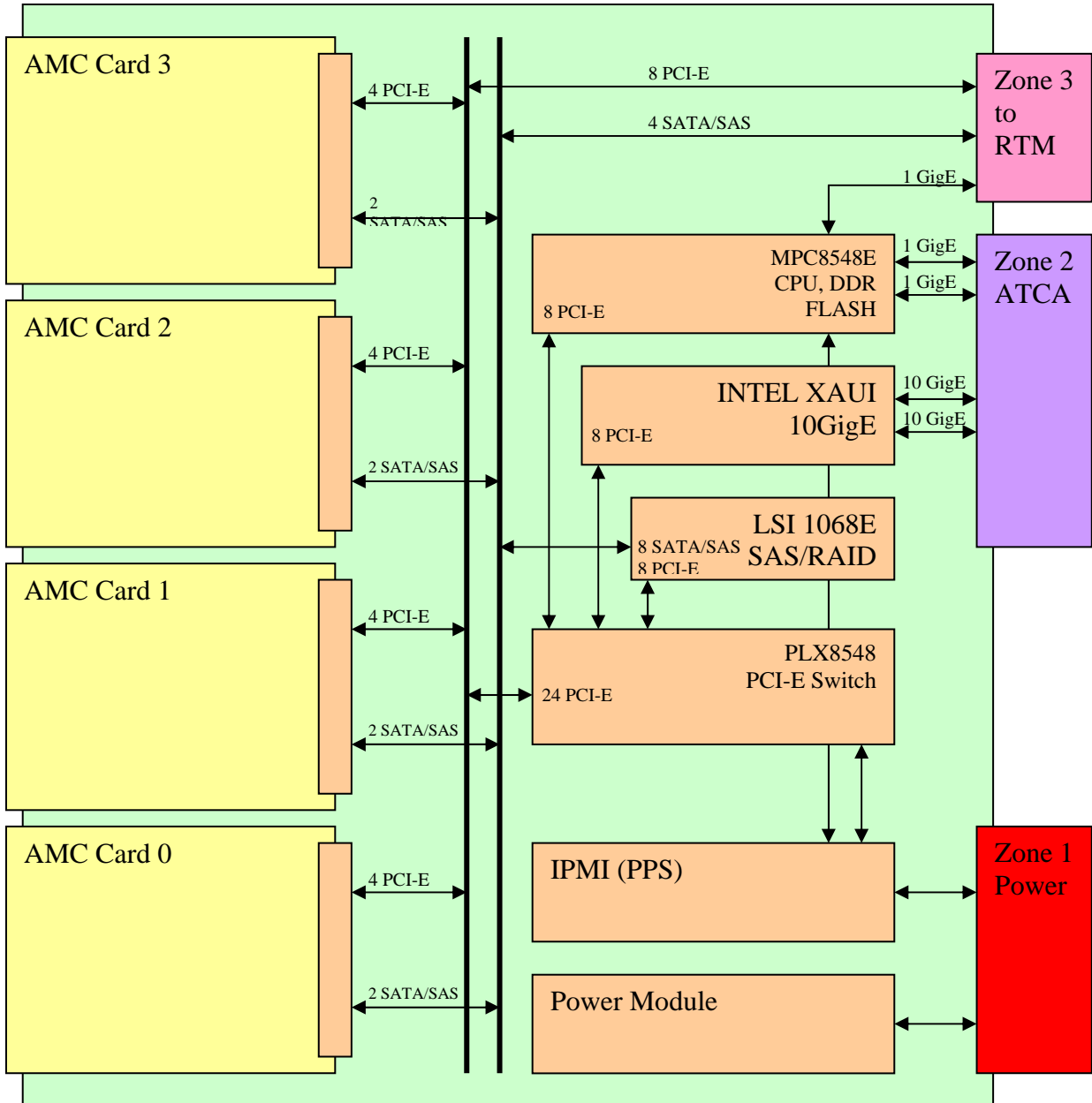

# SB ATCA1000 Storage Blade

## Technical Specifications

### PROCESSOR

Freescale Power QUICC III MPC8548 running at up to 1.2 GHz  
32KB Separate L1 instruction and data cache  
512KB L2 Cache  
Ethernet and PCI Express Interfaces

### SDRAM

Up to 1GB DDR memory with Error Checking and Correction (ECC)  
Modular and upgradeable 200 pin SODIM packaging  
Up to 266MHz

### FLASH

256K Bytes NAND Flash  
8KB Non-Volatile Serial EEPROM

### COMMON OPTIONS

Two GigE Ports to the ATCA Backplane Base  
Two 10GigE Ports to the ATCA Backplane Fabric

### STORAGE OPTIONS

Four AMC Card Slots  
20 Watts per Slot  
Two SAS/SATA Ports per Slot  
Four PCI-Express Lanes to each Slot  
IPMI Local Management

### COMMON OPTIONS – PCI EXPRESS SWITCH

PLX Technology PEX8548 48 Lane PCI Express Switch  
Eeprom Interface Signals  
Compliant with PCI Express Base 1.0a  
One Port to Each AMC Module  
Four Lanes per AMC Module Port  
One Port to RTM  
Eight Lanes to RTM  
Eight Lanes to Power QUICC III  
Eight Lanes to XAUI

### XAUI FABRIC – FAT PIPES REGION

Intel 82598 10GigE  
Eight PCI Express Lanes to Switch  
Eeprom storage

### EXPANSION

Up to Four AMC Modules  
Up to Four PCI Express Lanes per Module  
Eight SAS/SATA Ports Per Module  
Four SAS/STAT Ports to RTM  
RTM Module  
Up to Eight PCI Express Lanes to RTM  
IPMP\_L Interface between the carrier and AMC Modules

### MANAGEMENT

Intelligent Platform Management Controller (IPMC)  
Conformance to ATCA Base Specification PICMG 3.0, Rev 2.0  
Dual Redundant IPMB A/B Interfaces  
E-Keying Features  
Hot Swap not supported

### LEDS AND SWITCHES

ATCA Failure / Out of Service  
ATCA LED 2 User Defined  
ATCA LED 3 User Defined

### PHYSICAL

ATCA PICMG 3.1 Form Factor  
Mid-Size AMC Module Support  
Power Requirements – 210 Watts Max, 120 Watts Nominal

Specifications are subject to change.



SANBlaze is a leading provider of storage solutions for embedded systems, delivering high performance enterprise storage technologies and functionality to the embedded computing market. Our AMC, PMC, ATCA and cPCI board level storage solutions provide maximum design flexibility, ease of integration and cost effectiveness.

SANBlaze Technology, Inc. ♦ 2 Clock Tower Place, Ste 550 ♦ Maynard, MA 01754  
Web: [www.sanblaze.com](http://www.sanblaze.com) ♦ Email: [info@sanblaze.com](mailto:info@sanblaze.com) ♦ Tel: (978) 897-1888 ♦ Fax: (978) 897-3171

Copyright © 2007 SANBlaze Technology Inc. All rights reserved. Referenced products are trademarks or registered trademarks of their respective owners.