

Product Highlights

- Advanced RTM Board
- PCI Express x8, Molex® IPASS® (x8)
- SAS port (x4) , infiniband style
- Optional Hard Disk drive
- Pass-thru Console, LAN Management
- MMC

Key Applications

- ATCA In chassis AMC expansion
- PCIe-to-PCIe bridging
- SAS expansion
- Server blade PCIe Slot expansion

Features

- ATCA PICMG 3.0, Rev 2.0
- SATA/SATA disk option
- Temperature options 55, 70 or 85°C
- Rear panel status LEDs
- PCI Express link speeds 2.5 Gb/s
- SAS/SATA link speed (1.5G/3.0 Gb/s)
- Customizable FRU data
- Hot swappable
- RoHS compliant
- Integrated IPMI, Rev 1.5, 2.0
- OEM option, custom zone-3



Advanced TCA®

The **SANBlaze SB-ARTM403** is a Rear Transition Module (RTM) for AdvancedTCA systems; it provides several connections on the rear panel with pass-through signal routing to the front ATCA board, including SAS, PCI-express (PCIe), Serial console and 1 Gb Ethernet. All rear panel connectors are compatible with commodity off-the-shelf, non-proprietary cables.

The SB-ARTM403 fits several deployment configurations that extend functionality of SBC (single board computer) blades.

- Pair with the SANBlaze ATCA1010 PCI express expansion carrier blade to add 4 AMC peripherals.
- Pair with the SANBlaze ATCA1020 SAS JBOD blade to add 4 AMC in-chassis disks.
- Pair with the SANBlaze ATCA1020 SAS JBOD blade to add 4 AMC in-chassis disks.

The SB-ARTM403 provides an MMC implementation that is modeled after the AdvancedMC specification. Thus an ATCA board can utilize the same management functions used for traditional AMC modules.

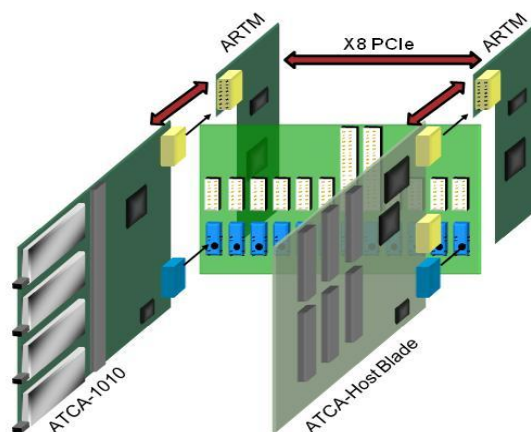

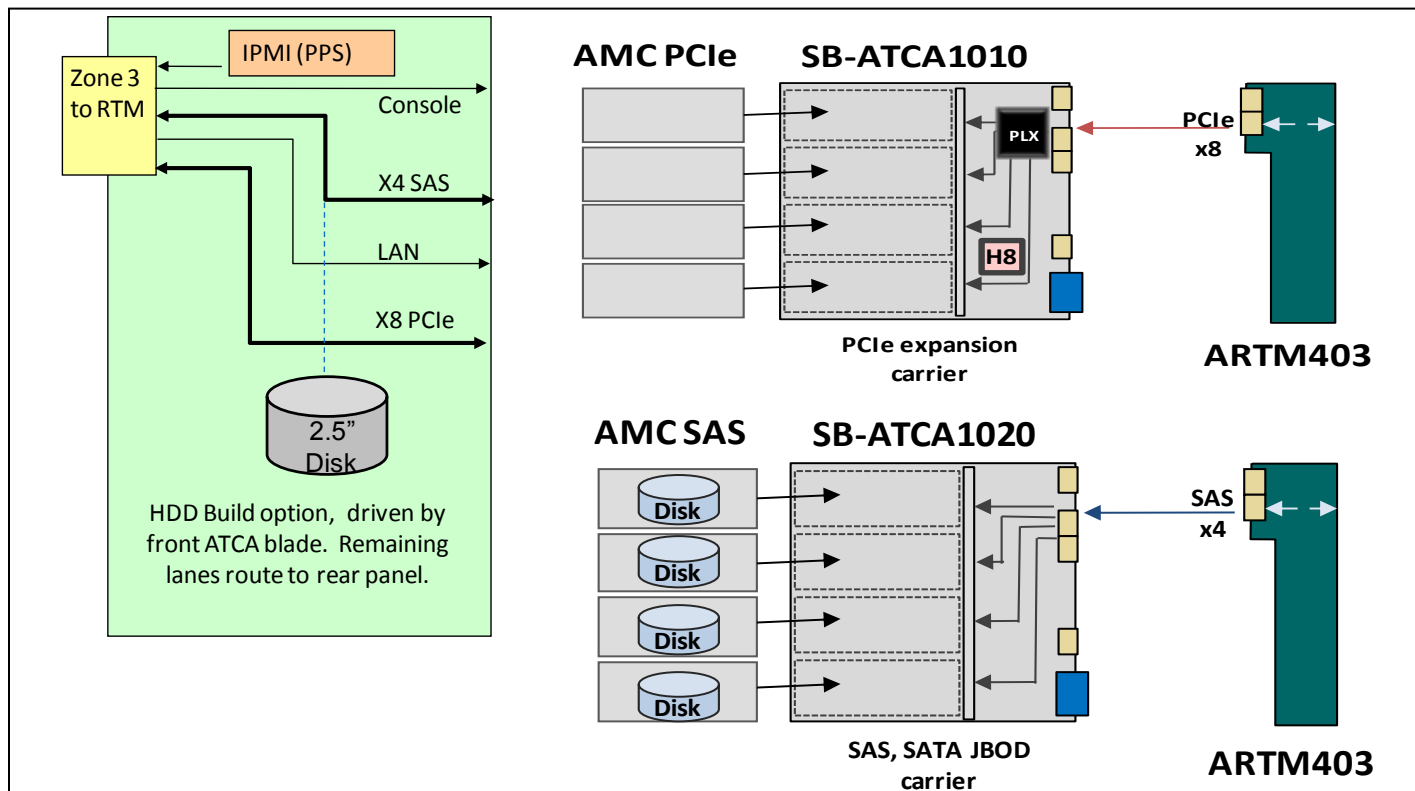

ARTM403 Block Diagram and Deployment Concept

Technical Specifications:

REAR PANEL CONNECTIONS		MANAGEMENT		
X8 PCI Express connector, 68 pin Molex ipass X4 infiniband (IB) style SAS connector RJ45 LAN pass through to ATCA zone 3 RJ45 console pass through to ATCA zone 3		Intelligent Platform Management Controller (IPMC) Dual Redundant IPMB A/B Interfaces E-Keying Features		
PHYSICAL		LEDS AND SWITCHES		
ATCA PICMG 3.1 Form Factor 6U x 70mm Power Requirements – 1 Max watts without drive – 4 Max watts with drive option		ARTM Failure / Out of Service (OOS) ARTM Ready LED ARTM blue hot swap LED ARTM PCIe cable detect LED		
ORDERING INFORMATION:				
Base Part number	Rear Panel connector Option*	Drive capacity (GB)	Suffix	Description
SB-ARTM403	A = PCI & SAS connector S =SAS Connector P = PCI connector	000	None	No Disk
		080,120,160,200,320	None	Standard duty SATA disk (55°C)
		080,120,160	X	Extended duty SATA disk (55°C)
		080	E	Extreme duty SATA disk (85°C)
		032,064,128	S	Standard Duty SSD (70°C)
		032,064,128	N	Extreme Duty SSD (85°C)
		036,073,146	Z	SAS disk (55°C)

For more information please visit the SANBlaze web site at: www.sanblaze.com or send email info@sanblaze.com.

SANBlaze is a leading provider of storage solutions for embedded systems, delivering high performance enterprise storage technologies and functionality to the embedded computing market. Our AMC, PMC, ATCA and cPCI board level storage solutions provide maximum design flexibility, ease of integration and cost effectiveness.



SANBlaze Technology, Inc. • 5 Clock Tower Place, Suite 100 • Maynard, MA. 01754 • Ph: (978) 897-1888 • Fax: (978) 897-3171