

### **Product Highlights**

- Eight 1000Base-T ports (RJ45)
- Two 1000Base-SX ports (SFP)
- One USB management port (Type A)
- Console management port (RJ45)

### **Key Applications**

- LAN aggregation functions
- Virtualized server I/O features
- Multi-core processor environments
- Server clustering

### **Features**

- ATCA PICMG 3.0, Rev 2.0
- Integrated IPMI, Rev 1.5
- 4 Intel® 82576 Ethernet controllers
- IPv4 and IPv6 offloading
- IEEE 802.3ad (link aggregation)
- IEEE 802.1p
- Virtual Machine Device queues (VMDq)
- Packet filtering capability
- iSCSI remote boot support
- PXE boot (Preboot eXecution)
- Non-volatile memory for initialization
- RoHS compliant
- Console for front blade management
- USB for front blade management
- Link/port status LEDs for all LAN ports
- Customizable FRU data

### **Regulatory**

- RoHS 6/6
- IEC60950, EN60950
- EN55022, EN50024
- FCC, VCCI, EN5022 (Class A)
- Designed for NEBs compliance

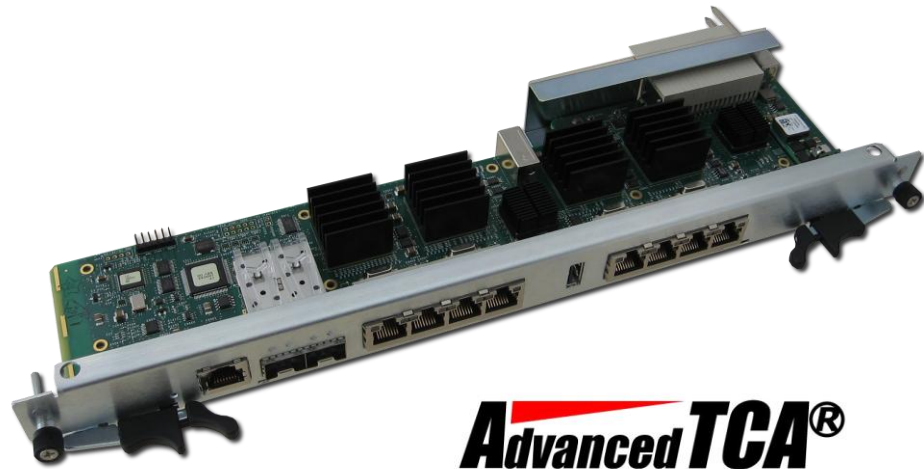

### **Eight 1000Base-T Ethernet Ports**

The **SANBlaze SB-RTM440** is a Rear Transition Module (RTM) for AdvancedTCA systems; designed specifically to work with the RadiSys Promentum™ ATCA-4500 blade. The SB-RTM440 offers numerous GbE networking features for enterprise ATCA applications, including support for multi-core processors and optimizations for server virtualization.

Functionally, the SB-RTM440 utilizes two PCI Express x4 buses to connect with multiple independent Ethernet controllers. Each controller supports a 1000Base-T Ethernet connection via RJ45 copper media jacks accessed on the RTM back panel. These ports are compatible with commodity off-the-shelf, non-proprietary CAT-5E or better cables.

The SB-RTM440 includes several additional ports that facilitate pass-through connectivity between RTM panel and signals on the Zone-3 connector. These include one serial and USB port for blade console management, and two 1Gb Ethernet SFP. Users may optionally populate these SFP ports when operating with properly configured front blades.

Finally, the SB-RTM440 includes a modular management controller (MMC) and conforms to the PICMG 3.1 revision 2 specification.

ATCA carrier blades cards with proper zone-3 connector pin-outs can interoperate and achieve connectivity to all connectors on the RTM panel.

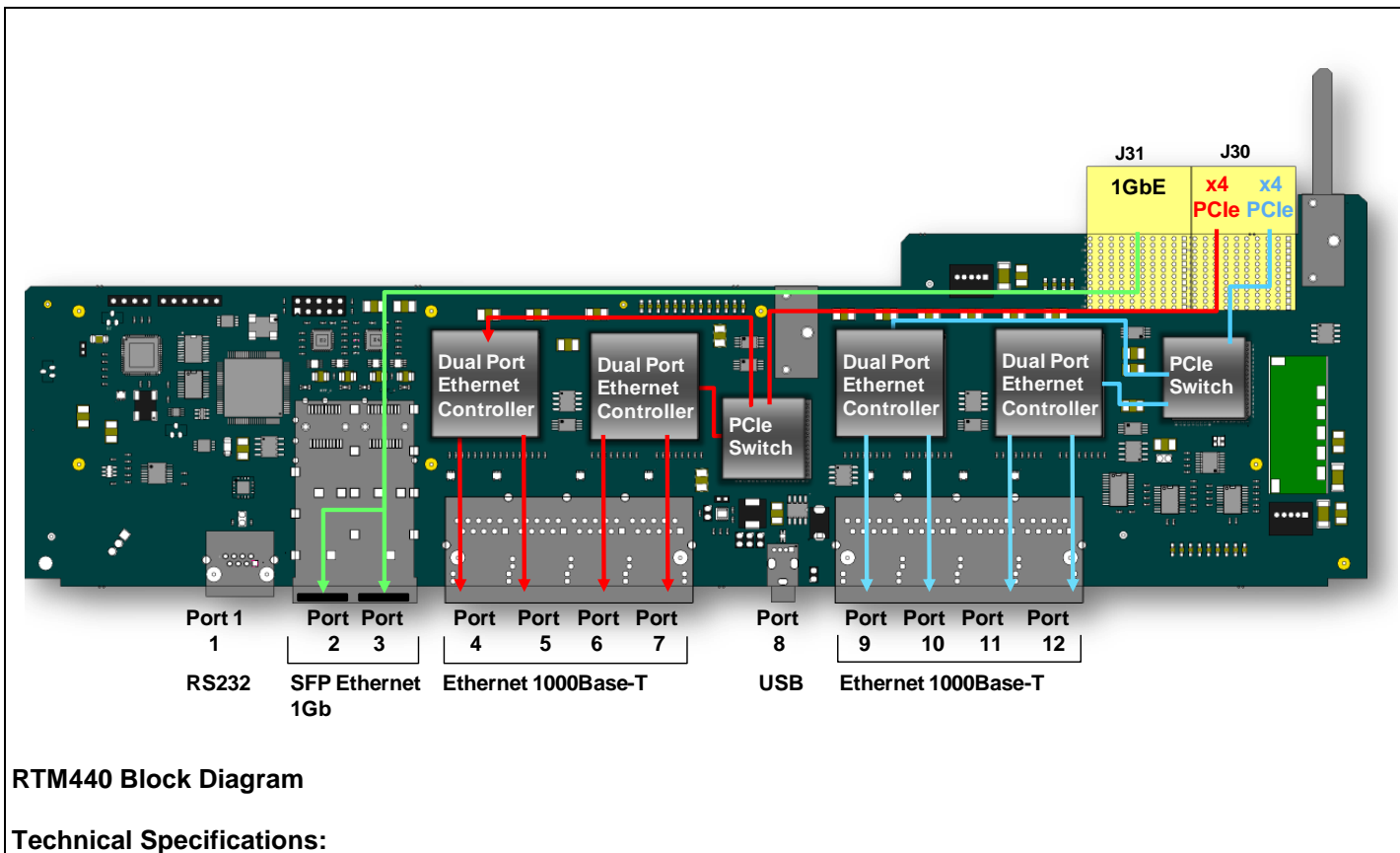

**RTM440 Block Diagram**

**Technical Specifications:**

REAR PANEL CONNECTIONS		MANAGEMENT	
Port 1 – RS232 (RJ45), pass through to ATCA zone 3 Port 2,3 Option: two 1Gb optical SX ports (see order info) Ports 4-7 1000BaseT Ethernet (RJ45) Port 8 – USB management (Type A), pass through to ATCA zone 3 Ports 9-12 1000BaseT Ethernet (RJ45)		Intelligent Platform Management Controller (IPMC) Dual Redundant IPMB A/B Interfaces E-Keying Features	
CABLING		LEDS	
100 meters, Category-5, unshielded twisted pair (UTP) , speeds 10/100/1000		RTM Failure / Out of Service (OOS) RTM Blue hot swap LED RTM Active (module power) Link status (Bi-color Green/Amber one for each Ethernet Port) Port status (Bi-color Green/Amber one for each Ethernet Port)	
Zone -3 FEATURES		PHYSICAL	
4 row connector IPMP_L Interface between the carrier and RTM Modules Two PCI Express x4, 2.5Gbps per lane		ATCA PICMG 3.1 Form Factor 6U x 70mm Power Requirements – 25 Max watts Operating temperature: 0° C to 55° C	
OS DRIVERS			
Linux® RHEL 4,5, Linux SLES 9,10 Windows server ©2003 and 2008			
ORDERING INFORMATION:			
Base Part number	SFP	Subassembly model	Description
<b>SB-RTM440</b>	None	<b>600-440000</b>	RTM without SFP populated
<b>SB-RTM440S</b>	Pair, 880nm SX SFP	<b>600-440000</b>	RTM with SFP populated

For more information please visit the SANBlaze web site at: [www.sanblaze.com](http://www.sanblaze.com) or send email [info@sanblaze.com](mailto:info@sanblaze.com).



SANBlaze is a leading provider of storage solutions for embedded systems, delivering high performance enterprise storage technologies and functionality to the embedded computing market. Our AMC, PMC, ATCA and cPCI board level storage solutions provide maximum design flexibility, ease of integration and cost effectiveness.

SANBlaze Technology, Inc. • 5 Clock Tower Place, Suite 100 • Maynard, MA. 01754 • Ph: (978) 897-1888 • Fax: (978) 897-3171